

ESW-3227 MID-POSITION SCISSOR LIFT

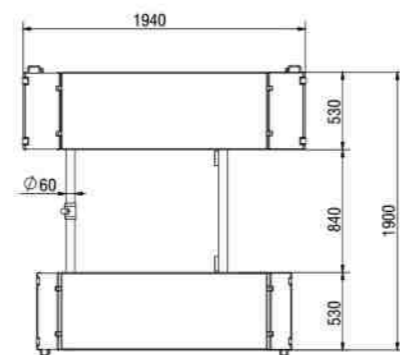
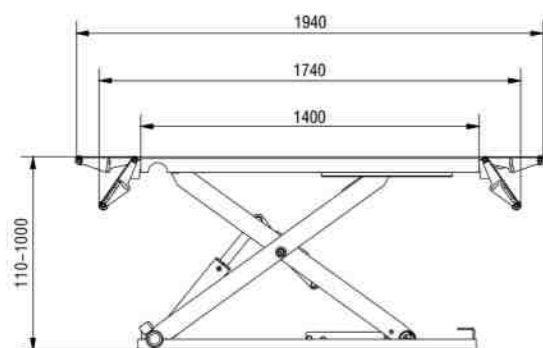

Features:

- 1.The lifting platform extension, according to the different models of the vehicle support the ramp and extension, flexible use, cover small space.
- 2.Pneumatic release, safe and reliable.
- 3.The initial height is lower (110mm), have sliding ramp and extension.
- 4.Adopt axis driven, synchronization performance good, lifting capacity well.
- 5.Hydraulic system adopted imported electromagnetic valve and seal components, ensure the stability and working life of the machine.
- 6.When the power supply is off, lift and vehicle can be down by manual.
- 7.Rising and falling have safety alarm device.
- 8.Oil cylinder with upper return oil, prevent oil cylinder rust.

Technical specifications:

Lifting capacity:	3000kg
Lifting height:	1000mm
Min.height:	110mm
Lifting time:	50s
Length of the platform:	1400mm
Platform width:	530mm
Motor power:	3.0kw-380v/3.0kw-220v
Oil pressure rating:	24Mpa
Air pressure:	0.6-0.8 MPa
Weight:	580kg



Moving wheel

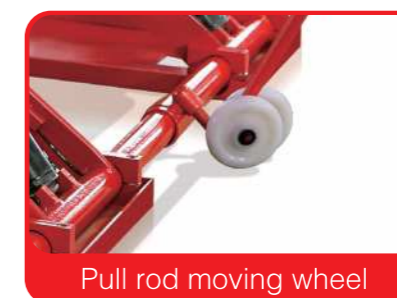

Pull rod moving wheel



Power paw



Pneumatic release



Electric release(optional)



Emergency hand pump(optional)